

SYNTHESIS OF ALLELOPATHIC SUBSTANCES

R.V. VENKATESWARAN

**DEPARTMENT OF ORGANIC CHEMISTRY
INDIAN ASSOCIATION FOR THE CULTIVATION
OF SCIENCE
KOLKATA 700 032**

Science of Allelopathy

Among the many factors that adversely affect the healthy growth of crops and lead to heavy losses in quality and yield, weeds play a significant role. As such efficient weed management has become an important constituent of agricultural research. The efforts over the years have resulted in the development of a variety of chemicals as herbicides. However, the exceedingly high cost of such chemical control agents and the increasing awareness on their potential environment hazards have persuaded a fresh look at devising alternate ways of weed control. In this, the concept of allelopathy has taken strong roots during the last two decades.

Allelopathy is a science based on biochemical plant plant interactions including positive and negative

***effects.* Although the mechanism of how a plant systematically influences the growth of another in proximity is not fully understood, the consequences of such influences are anticipated to have far reaching implications in efficient future weed control. By virtue of their need to physically adopt themselves to the changing environments, plants develop their own system of self- defense and in the process become a source of a wide spectrum of organic chemicals of varying structural types, many of which turn out to be active allelopathic agents. Such compounds can also provide important leads in the development of new organochemicals as economically viable and environment friendly weed control agents.**

HELIANNUOLS - A NEW CLASS OF ALLELOPATHIC SUBSTANCES

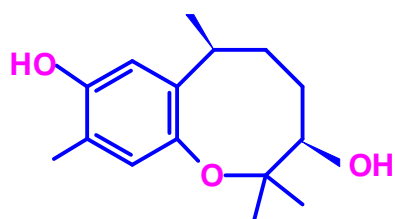

A

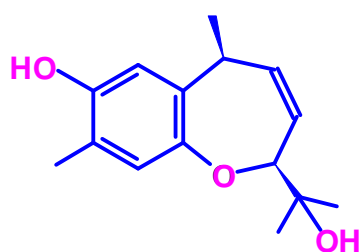

B

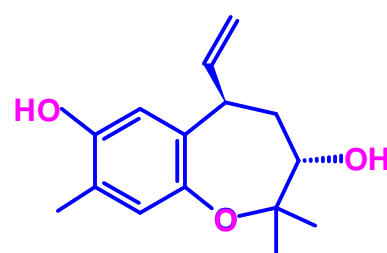

C

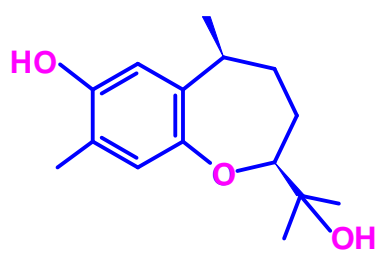

D

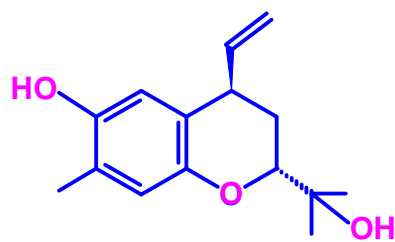

E

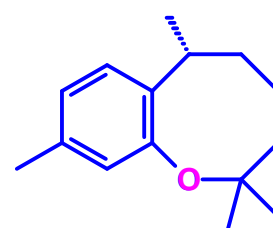

HELIANANE

1. Macias et.al., *T. Letters*, 1993, 34, 1999.
2. Macias et.al., *J. Org. Chem.*, 1994, 59, 8261.
3. Macias et. al., *T. Letters*, 1999, 40, 4725.
4. Harrison & Crews, *J. Org. Chem.*, 1997, 62, 2646

Initial abortive approach based on our previous synthesis of benzoxepinenones

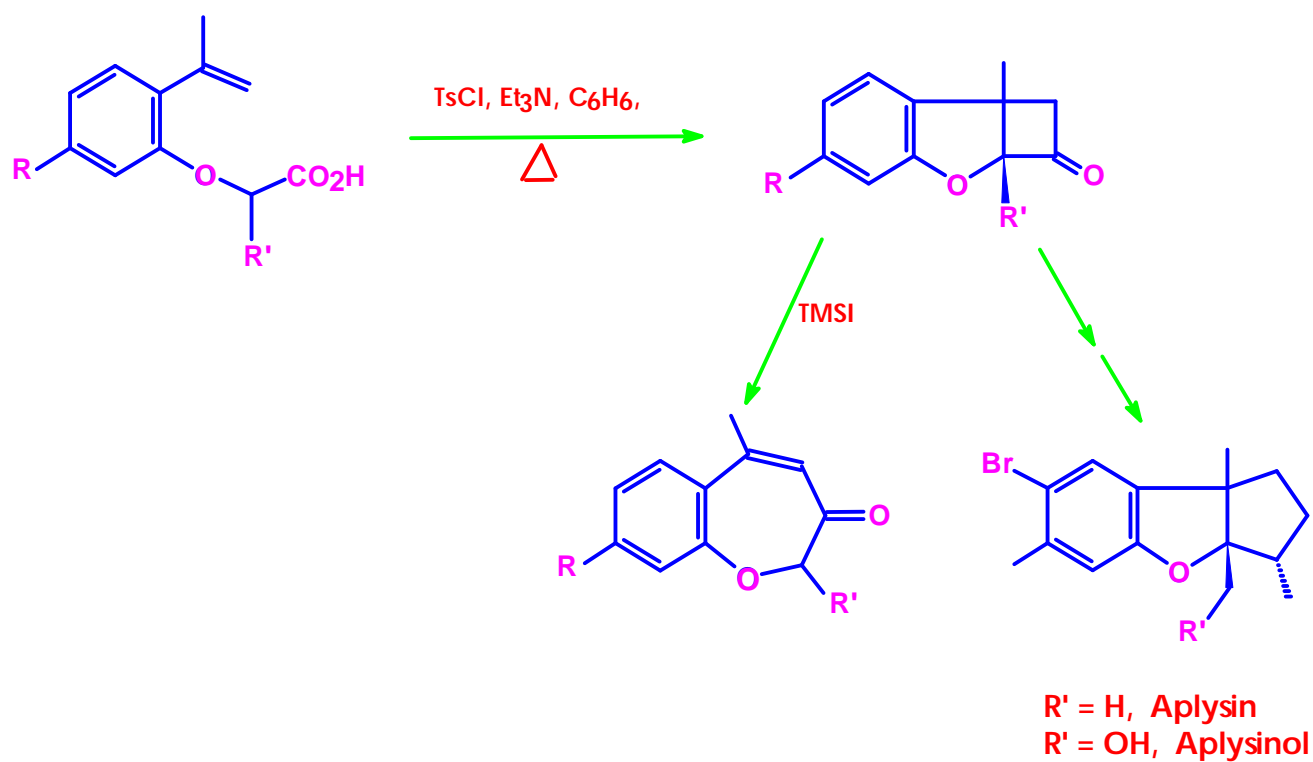

Venkateswaran et.al. *J. Org. Chem.* 1990, 55, 3498
J. Org. Chem. 1996, 61, 4391
J. Indian. Inst. Sc. 1994, 74, 199

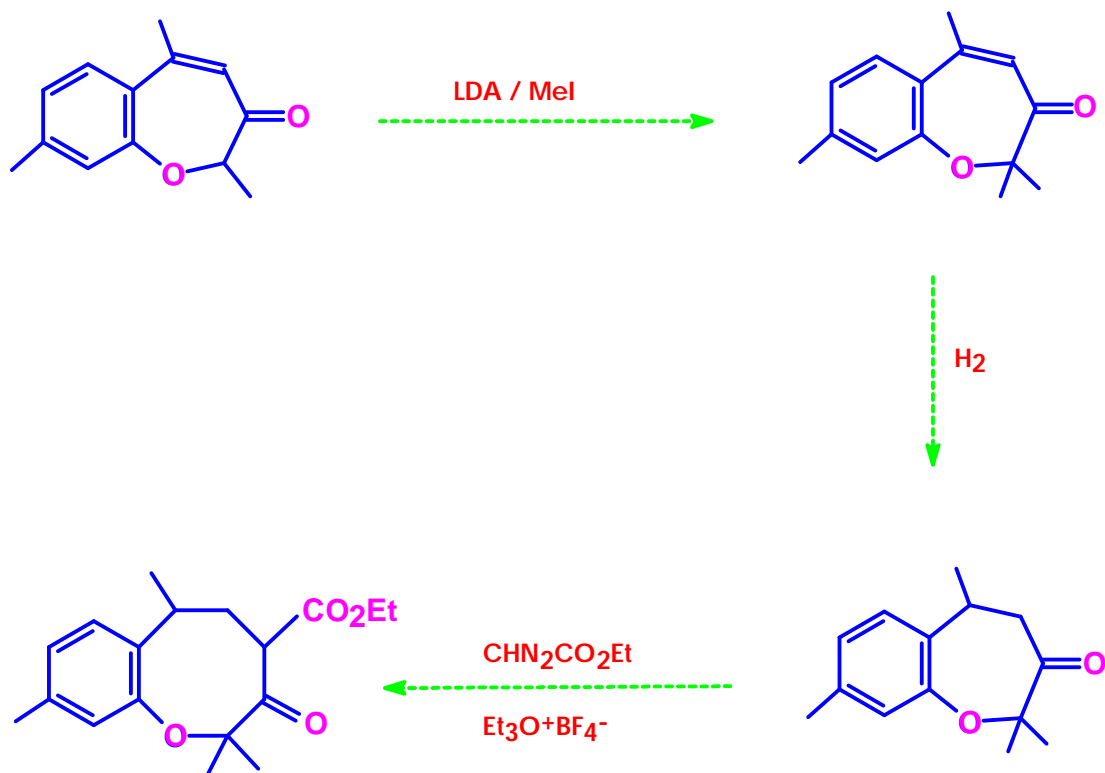

The desired methylation did not take place under a variety of conditions.

Alternate successful strategy:
Prior incorporation of *gem* - dimethyl group

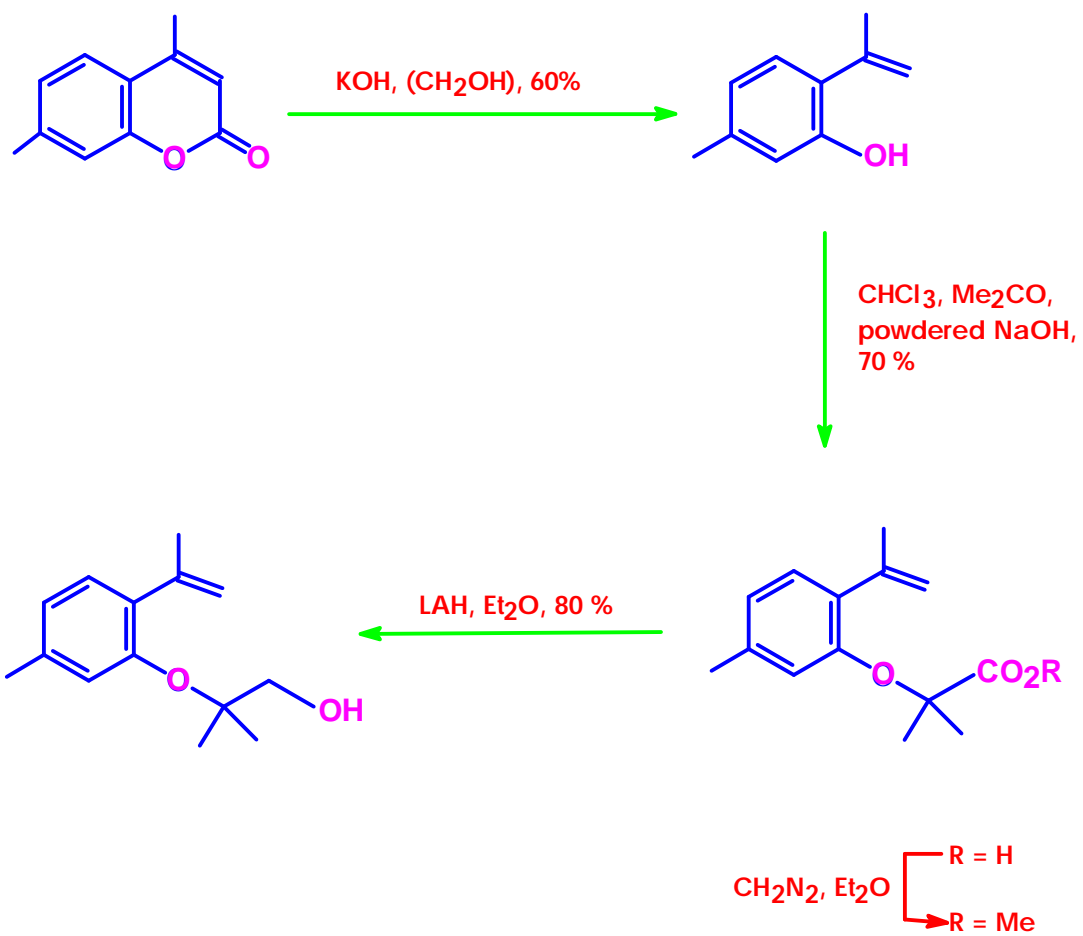

A fortuitous aldo - ene cyclisation

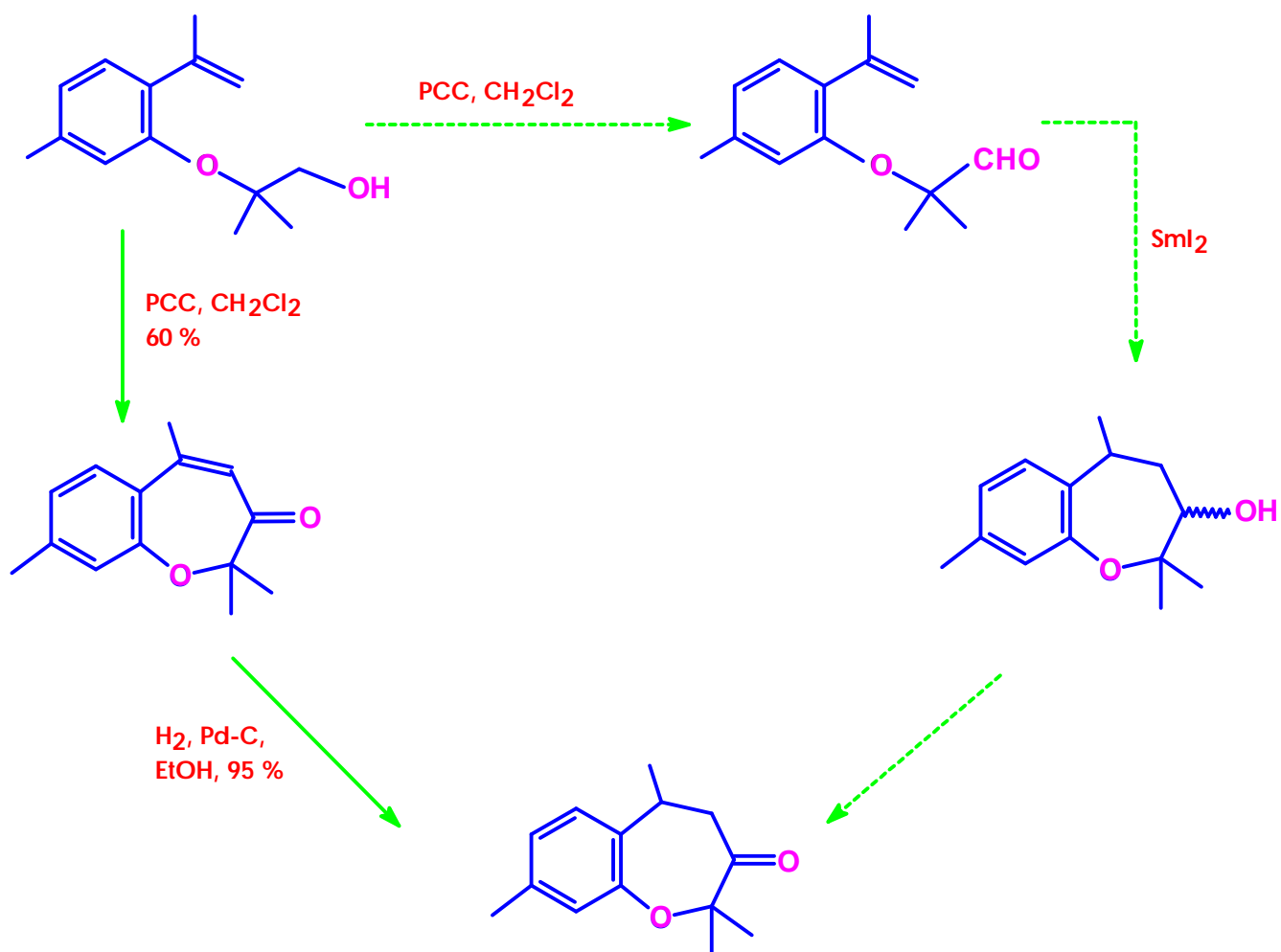

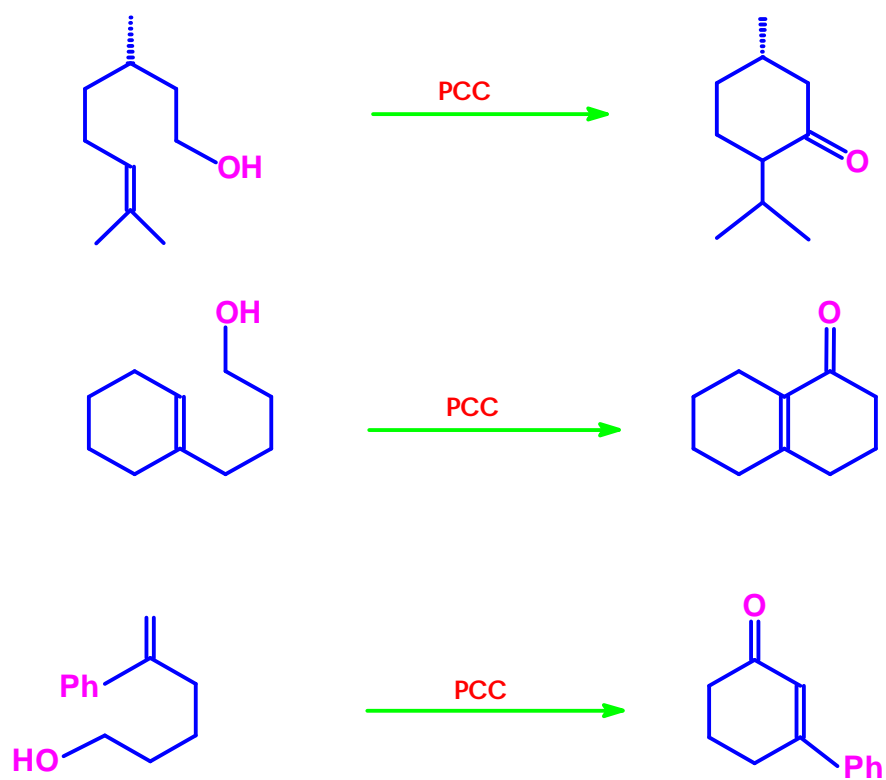
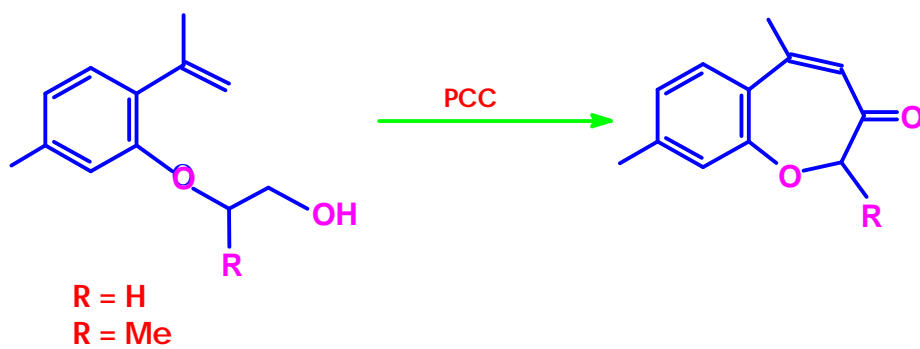

Corey et.al., *J. Org. Chem.*, 1976, 41, 380
Tetrahedron Letters, 1978, 2461

Development of the 8-membered benzoxacyclic ring system

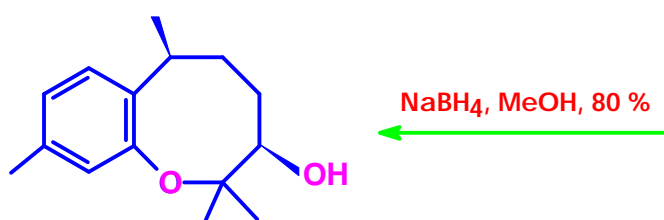
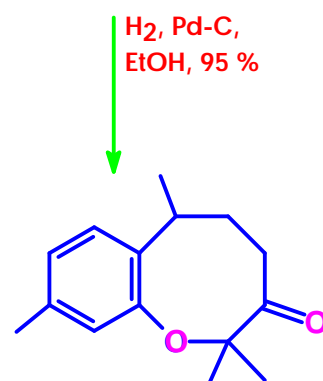
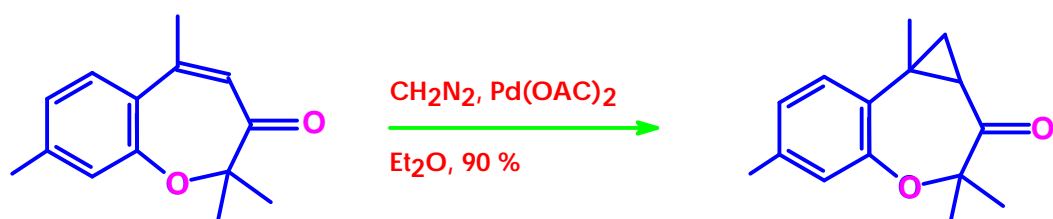
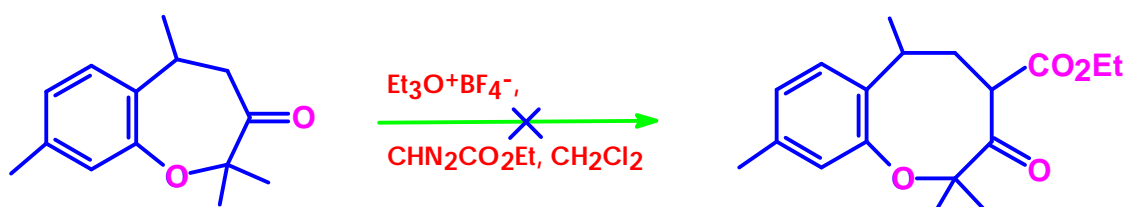

Transfer of the methodology to substituted precursor:
Synthesis of heliannuol A

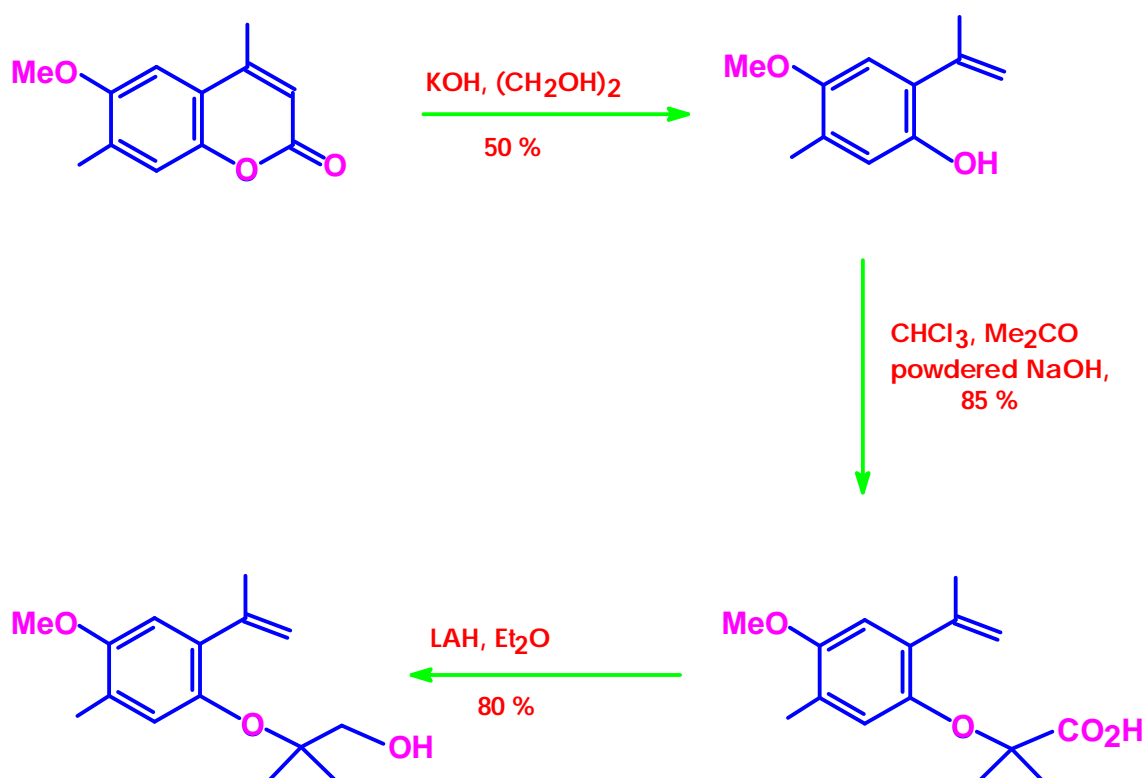

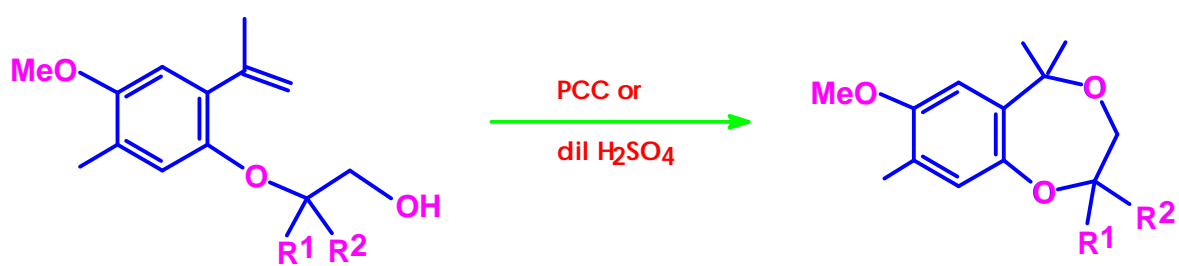
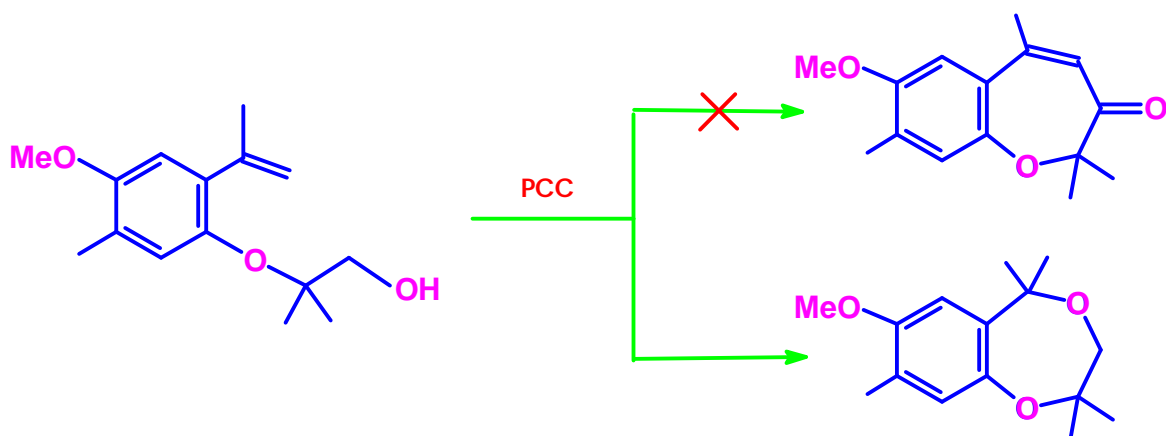

$\text{R}_1 = \text{R}_2 = \text{H}$
 $\text{R}_1 = \text{H}; \text{R}_2 = \text{Me}$
 $\text{R}_1 = \text{R}_2 = \text{Me}$

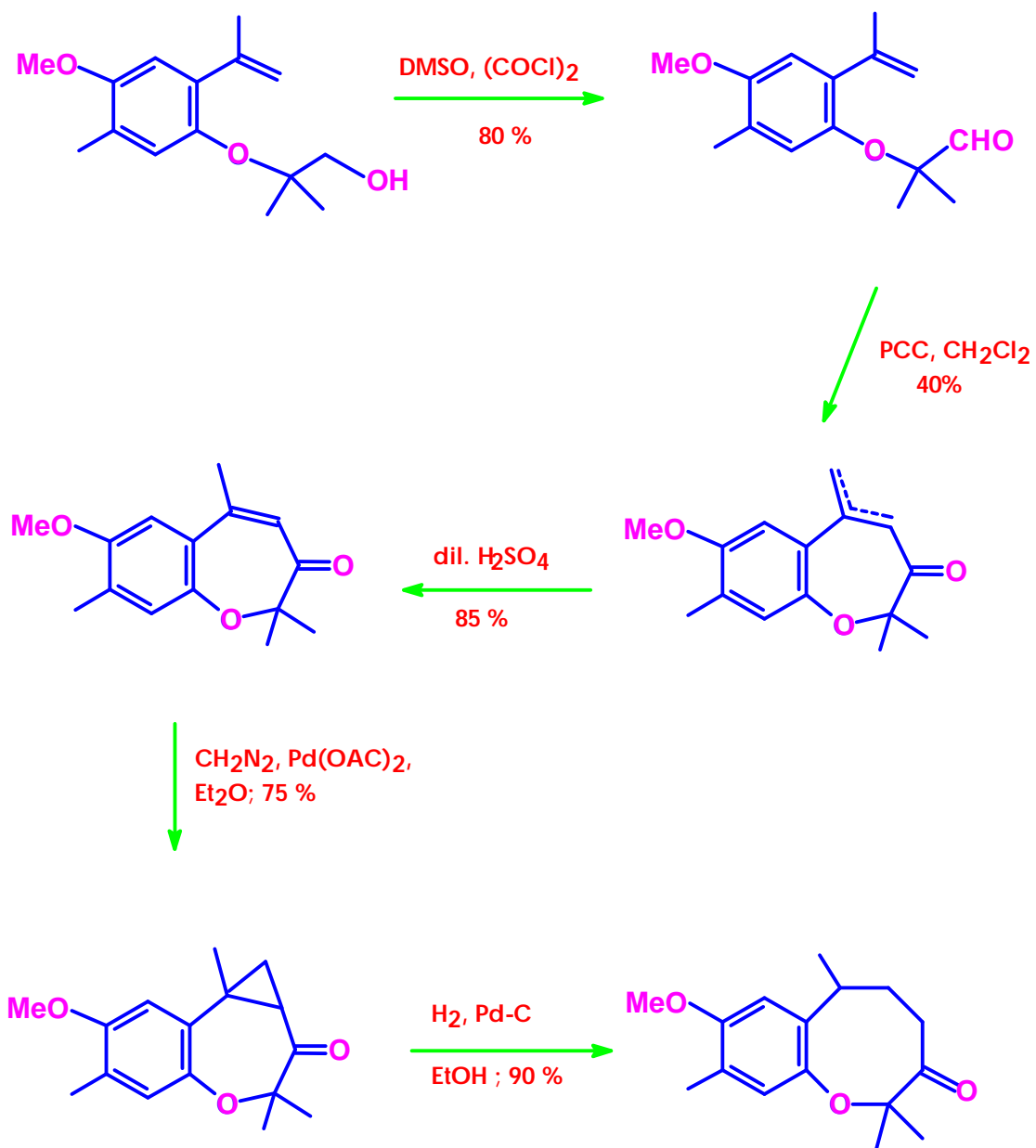

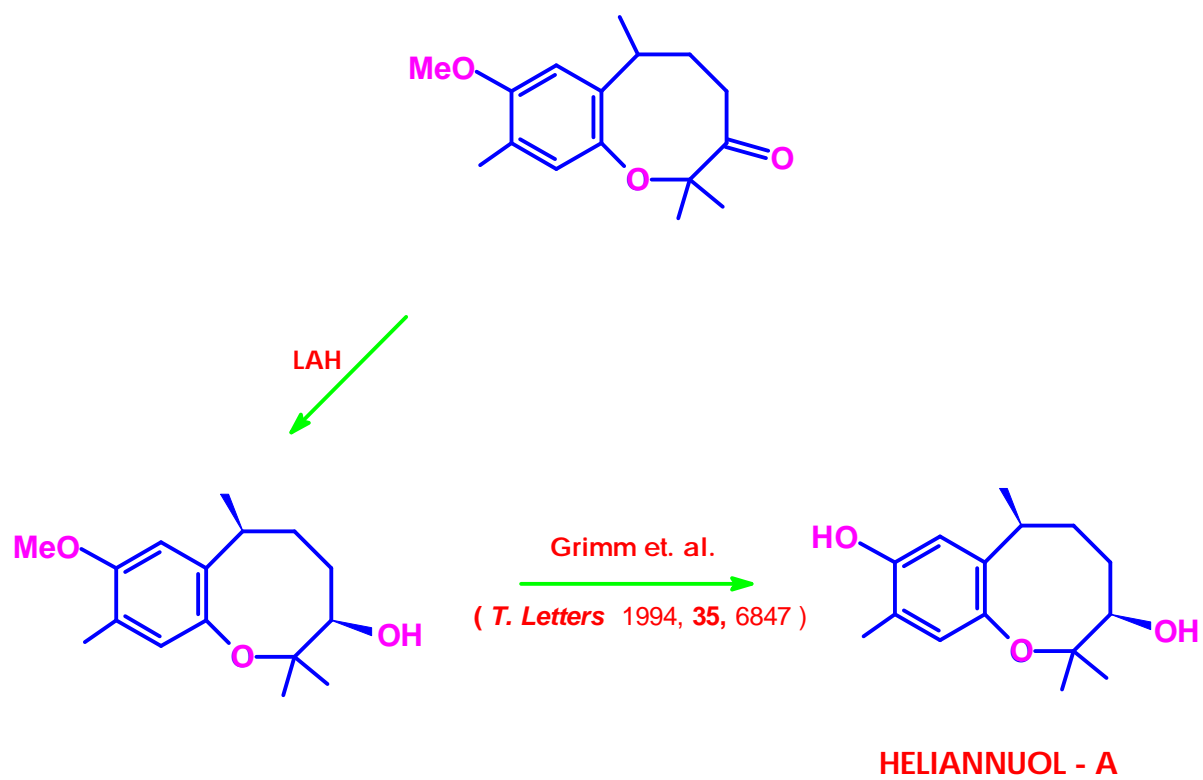

A novel radical induced fragmentation

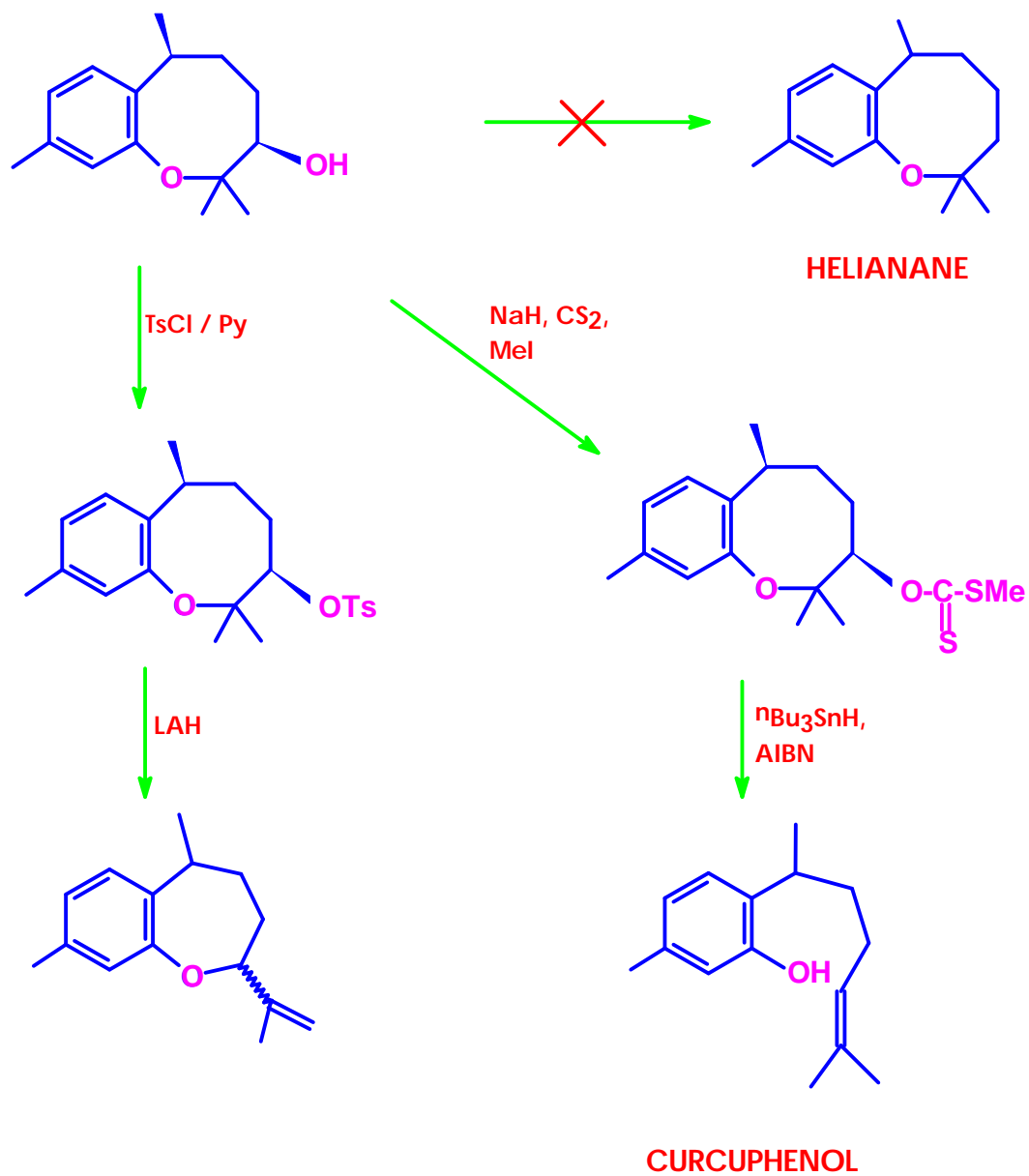

A Formal Synthesis of Heliannuol D

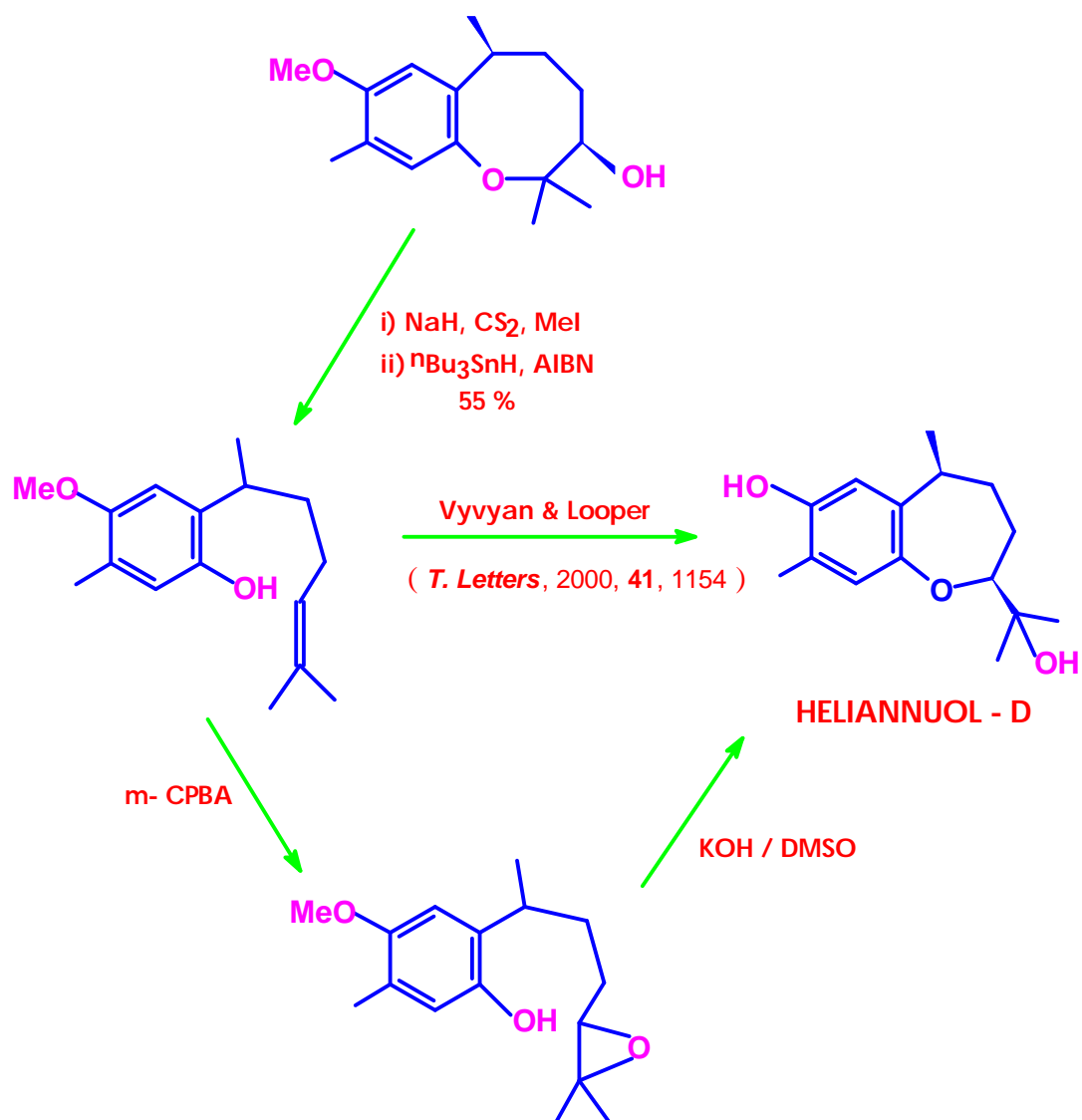

Tuhina, Bhowmik & Venkateswaran, *Chem.Comm.* 2002, 634